

COMMERCIAL

ERV

**330 ERV-ECM
530 ERV-ECM
730 ERV-ECM
1230 ERV-ECM**

Installation Manual

Pre-Installation Notes



Note

- Due to ongoing research and product development, specifications, ratings, and dimensions are subject to change without notice. Refer to <https://www.lifebreath.com> for the latest product information.



Attention

- Do not apply electrical power to the unit until after the completion of the installation (including installation of low voltage control wiring).
- Ensure the installation and wiring is in accordance with all local electrical codes.
- Plug the unit into a standard designated (120 VAC) electrical outlet with ground.
- The use of an extension cord with this unit is not recommended. If the installation requires further wiring, have a licensed electrician make all the electrical connections. The recommended circuit is a separate 15A/120V (25A/120V for 1230ERV-ECM) circuit.



Caution

- Before installation, careful consideration must be given to how this system will operate if connected to any other piece of mechanical equipment, i.e. a forced air furnace or air handler, operating at a higher static. After installation, the compatibility of the two pieces of equipment must be confirmed, by measuring the airflows of the ERV, by using the balancing procedure found in this manual. Never install a ventilator in a situation where its normal operation, lack of operation or partial failure may result in the back drafting or improper functioning of vented combustion equipment
- Unit must be installed level. Due to the broad range of installation and operational conditions, consider the possibility of condensation forming on either the unit or connecting ducting. Objects below the installation may be exposed to condensate.
- Do not install control wiring alongside line voltage electrical wire.



Warning

- Disconnect the power from the unit before cleaning or servicing.
- To prevent electrical shock, it is extremely important to confirm the polarity of the power line that is switched by the safety (disconnect) switch. The hot line (black) is the proper line for switching. Use either a voltmeter or test lamp to confirm the absence of a voltage between the disconnect switch and ground (on the cabinet) while the door is open. This procedure must be followed, as dwellings are occasionally wired improperly. Always ensure the proper grounding of the unit.
- Improper installation, adjustment, alteration, service or maintenance can cause property damage, personal injury or loss of life. Installation and service must be performed by a qualified installer or service agency.

Table of Contents

1	Location Notes	3
2	Ducting the System	4
3	Dimensional Drawings	5
3	Dimensional Drawings	6
4	The Integrated HVAC System.....	7
5	The Integrated HVAC System.....	8
6	Stale Air Return and Fresh Air Supply System	9
7	Weatherhoods and Grilles	10
8	Electrical Connections	11
9	Functions and Controls	12
10	Main Wall Control	13
11	Main Wall Control	14
12	Main Wall Control	15
13	Main Wall Control	16
14	Main Wall Control	17
15	Timers and Repeaters	18
16	Timers and Repeaters	19
17	Timers and Repeaters	20
18	Timers and Repeaters	21
19	Aircon Relays & Interlocking to a furnace/air handler	22
20	Fan Defrost.....	23
21	Balancing the Airflows	24
22	Balancing the Airflows	25
23	Service and Maintenance.....	26
24	Service and Maintenance.....	27
25	Reverse Installation of the ERV.....	28
26	Troubleshooting.....	29
27	Troubleshooting.....	30
28	Wiring Diagrams (330ERV-ECM, 530ERV-ECM, 730ERV-ECM, 1230ERV-ECM)	31
29	Warranty.....	32



1 LOCATION NOTES

The unit must be in a heated space where the surrounding air temperature does not fall below 60°F (16°C). The warranty will be void if these conditions are not met. Typically, the unit is positioned close to an outside wall or the roof to simplify the connections and keep the length of insulated ducting required for the fresh air intake to a minimum.

A minimum clearance of 30 inches (76 cm) in front of the unit is recommended to service the heat exchanger cores and the filters. The unit may be mounted on an equipment platform providing there is enough space to open the doors for servicing.

Saddle Installation

- (1) Threaded rod (not supplied)
- (2) Vibration isolators (not supplied)

Hang unit with suspended rods and "U" channel members.

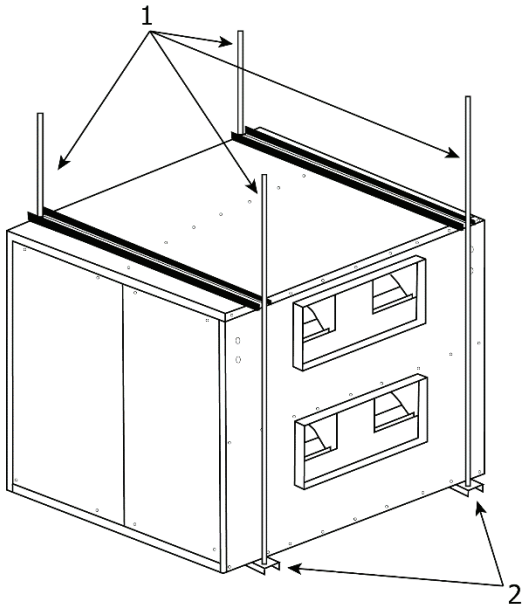

Curb Mounted Installation

- (1) Curb—Wood or Metal (not supplied)
- (2) Vibration isolators (not supplied)

Mount unit on wooden or metal curb assembly. May be anchored to floor.

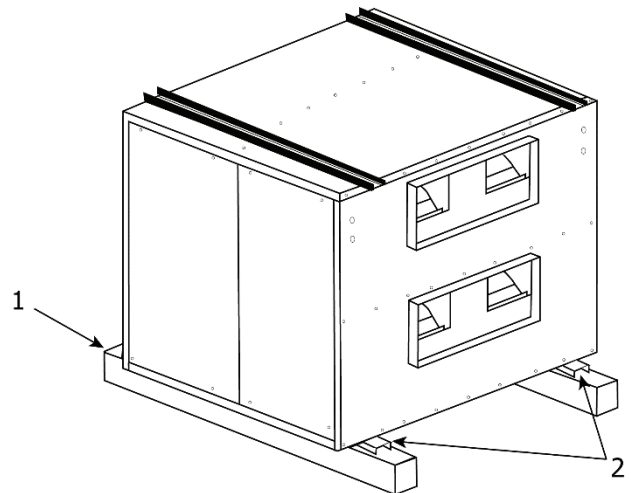

2 DUCTING THE SYSTEM

A properly designed ducting system will allow the ERV to operate at its maximum efficiency. (Air flow will be restricted by undersized ducting, use of too many elbows, tees, bends, etc.). Always try to keep duct runs as short and straight as possible.

All joints must be airtight, sealed and impervious to moisture. See [Dimensional Drawings](#) for each unit for exact duct sizes and location.

To minimize pressure drop and noise, galvanized metal ducts, properly sized, are recommended. Keep ducting as short as possible and use a minimum of elbows and tees.

Connecting sections and shorter runs may be flexible ducting one size larger than the metal equivalent. Use flexible duct connectors at the ERV to avoid noise transmission.

All duct joints must be secured with screws, rivets or duct sealant and sealed with aluminum duct tape to prevent leakage.



Attention

- Flexible duct connectors should be installed between the ERV and the galvanized ductwork.
- Use fully insulated ducting with an integral vapour barrier on all runs that pass through unheated areas to avoid condensation problems and energy losses from the air streams. Consult local codes.

3 DIMENSIONAL DRAWINGS

Airflow:

- ⇨ Stale Air to Outside
- ⇨ Fresh Air from Outside
- ⇨ Stale Air from Inside
- ⇨ Fresh Air to Inside

330ERV-ECM Dimensions:

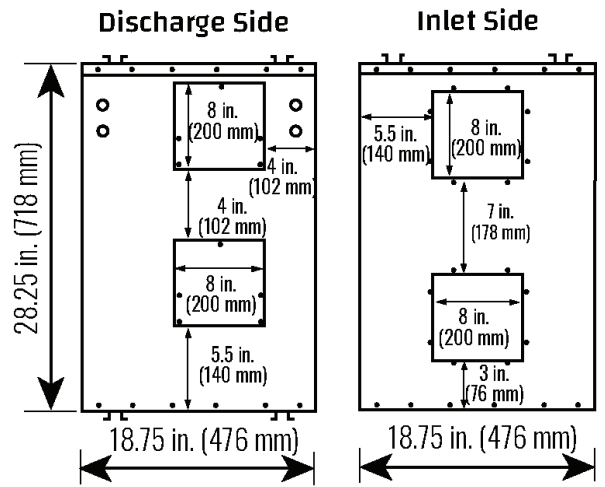
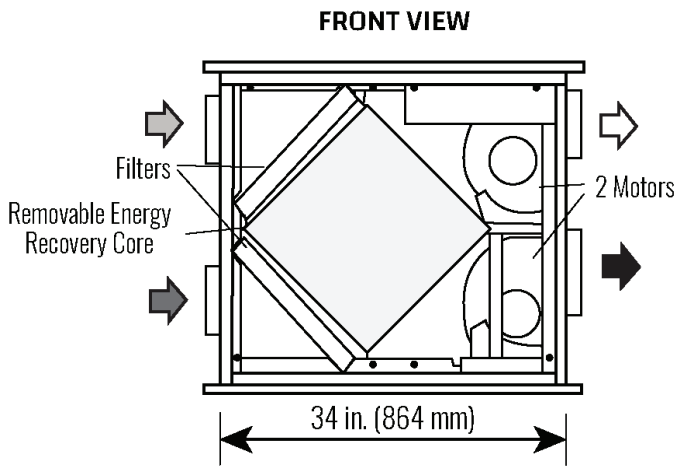

530ERV-ECM Dimensions:

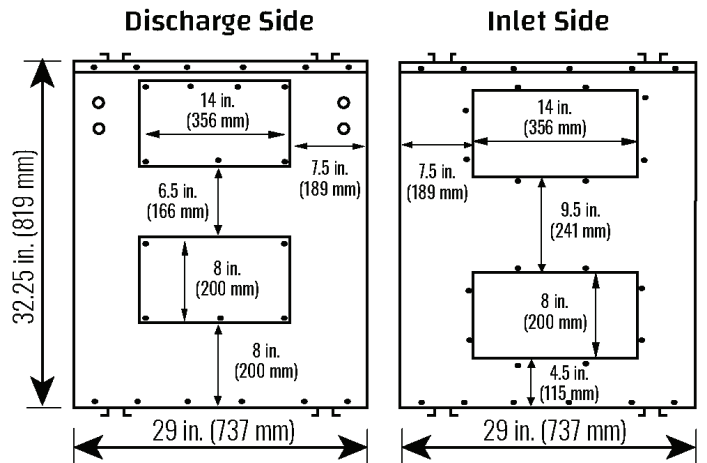
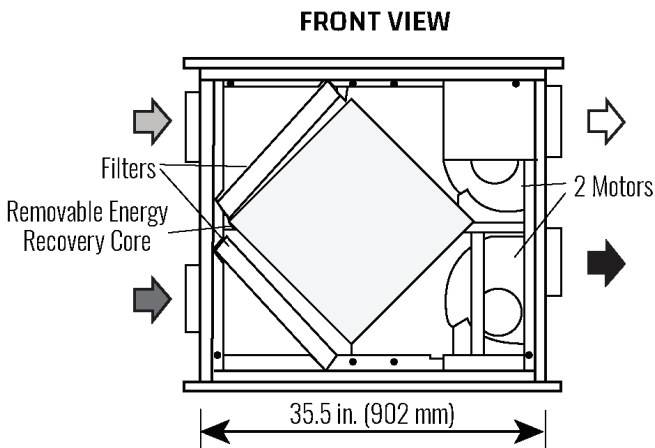

3 DIMENSIONAL DRAWINGS

Airflow:

- ⇨ Stale Air to Outside
- ⇨ Fresh Air from Outside
- ⇨ Stale Air from Inside
- ⇨ Fresh Air to Inside

730ERV-ECM Dimensions:

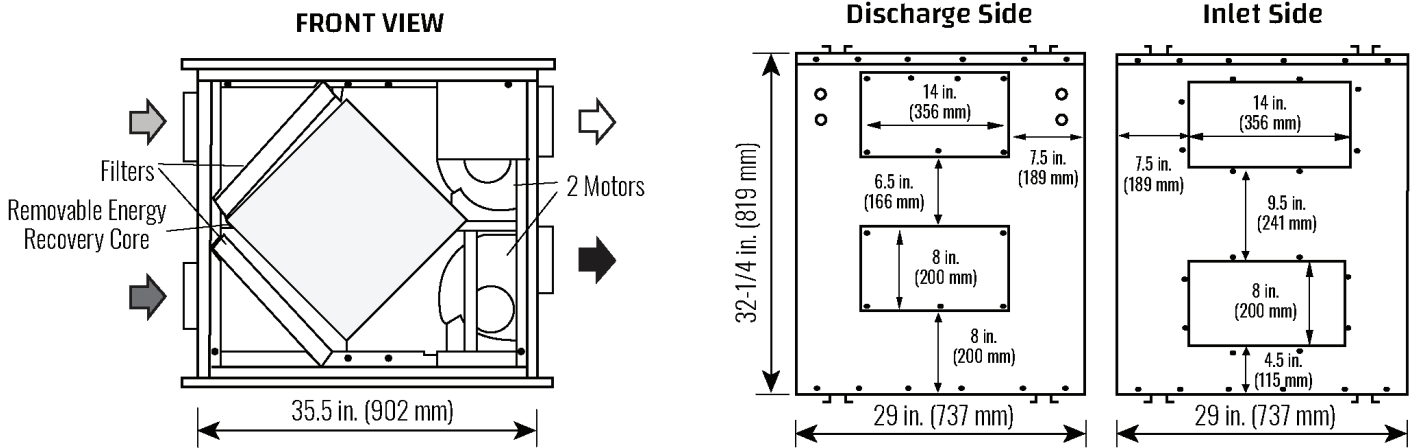

1230ERV-ECM Dimensions:

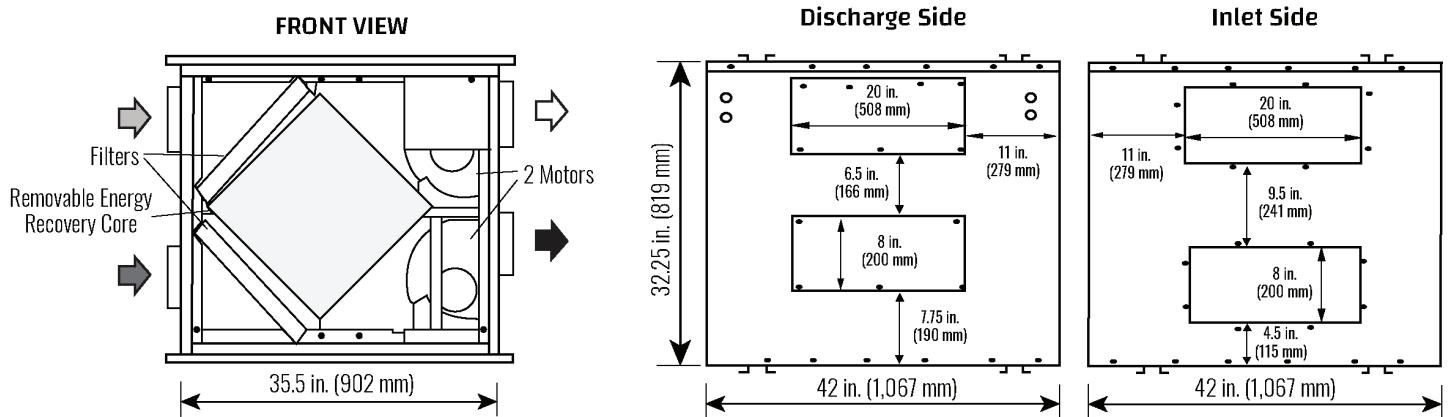

4 THE INTEGRATED HVAC SYSTEM

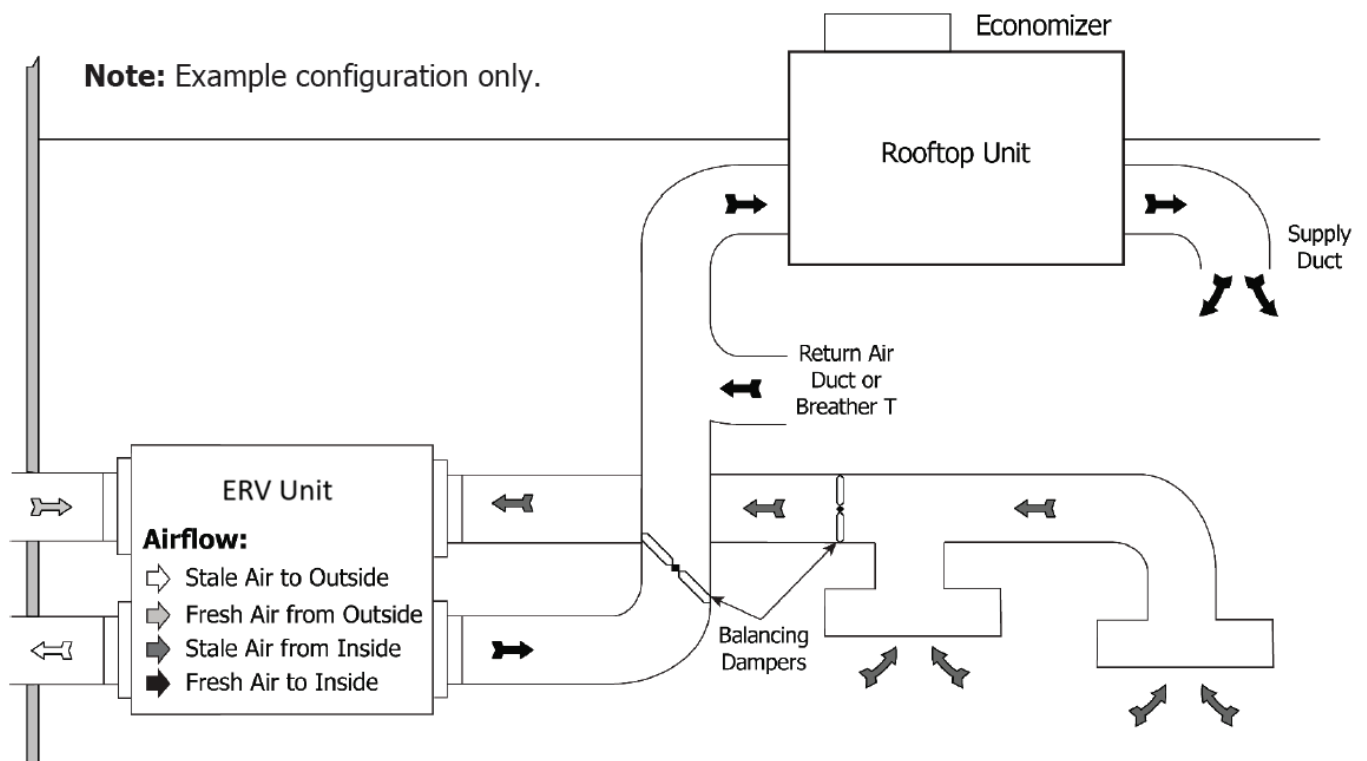

Figure A

The ERV has become an integral component of the HVAC system. Figure A shows an ERV unit providing fresh air directly to the return air plenum of a rooftop heat/cool unit.

In the balanced airflow system, the ERV exhaust removes stale room air (eg. from lunch room, storage or copy area) and returns to the space an equal amount of fresh outdoor air, making the use of an economizer obsolete in conjunction with an ERV.



Note

- At no time should the air handler T.E.S.P. on the return duct exceed that of the ERV.



Caution

- When interlocking a rooftop unit with an ERV take care to ensure the fans of both units operate in the correct rotation.

5 THE INTEGRATED HVAC SYSTEM

Note: Example configuration only.

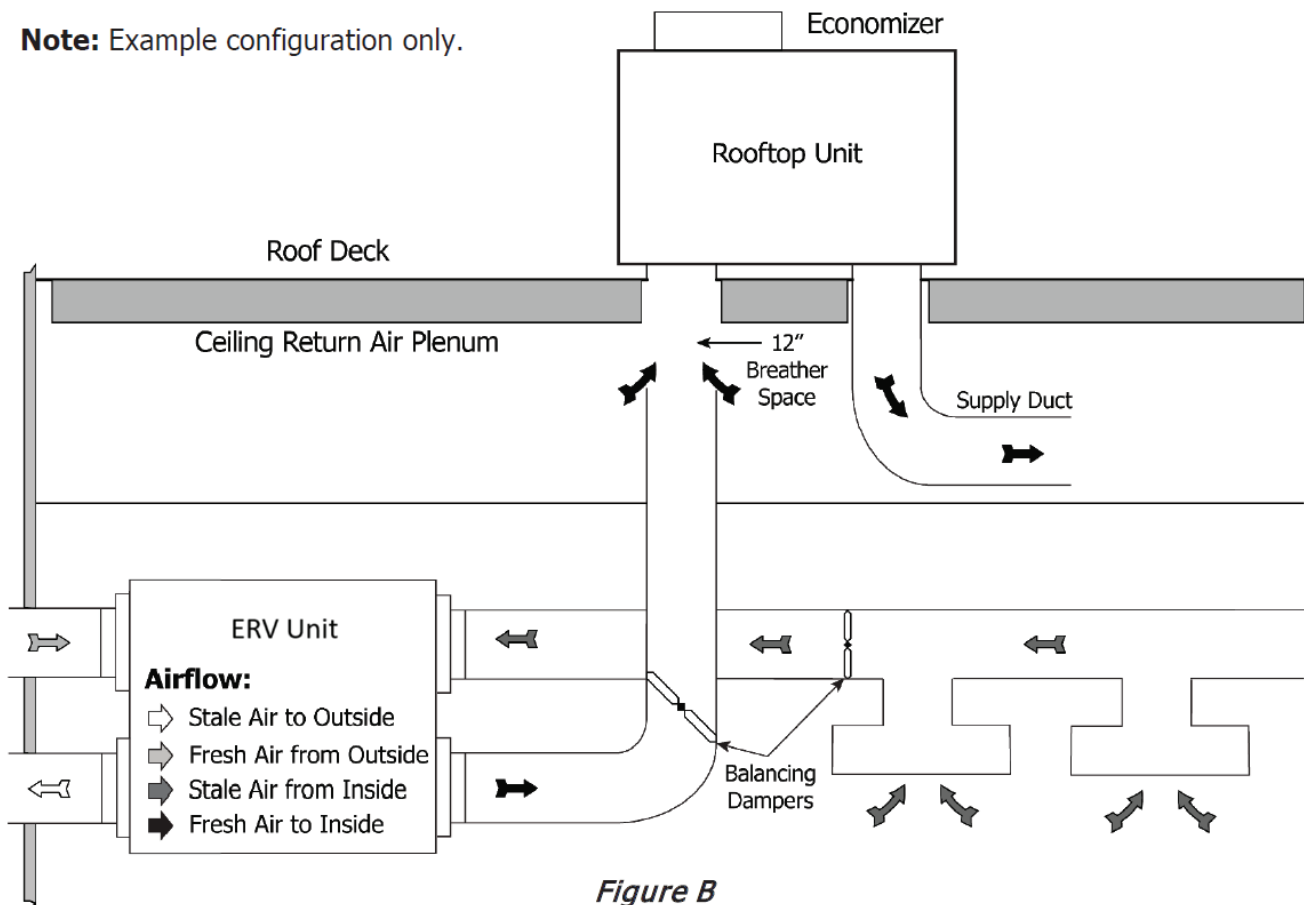

Many buildings have ceiling return air plenum as in Figure B. Fresh air from the ERV can be introduced directly into the ceiling space, but this should occur near the air handler's intake.

By operating the ERV on a 24 hour / 7 day battery backed timer, the unit can be set to operate only when occupancy or indoor conditions require the air exchange.

In installations where it is satisfactory to provide general exhaust from the space, the air to be exhausted may be taken directly from the return air plenum to the ERV as it is drawn back to the air handler. Fresh air supplied by the ERV is then introduced directly into the return air plenum but at a location closer to the air handler. The air handler would have a constant running blower to effectively distribute the fresh air and remove the stale air. Balancing dampers would be located in both the ERV supply and exhaust ducts between the return air plenum and the ERV.

6 STALE AIR RETURN AND FRESH AIR SUPPLY SYSTEM

Stale Air Return System

Many commercial activities produce air contaminants in the form of dusts, fumes, mists, vapors and gases. Contaminants should be controlled at the source, so they are not dispersed through the building or allowed to increase to toxic concentration levels. The ventilator allows for economical operation of the HVAC system while effectively removing contaminants from the space. In designing the exhaust portion of the system, the exhaust grilles are situated to remove the contaminants while not allowing them to enter the breathing zone of the occupants.

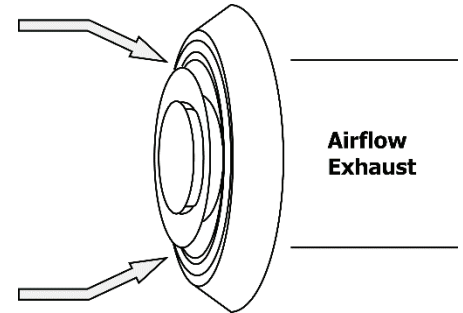

The stale air return system is used to draw air from the points in the building where the worst air quality problems occur. Balancing dampers and/or adjustable grilles are recommended on all return air lines which are used during installation to help balance the "draw" from different areas of the building.

For contaminants lighter than air, grilles should be located high on the wall. If contaminants are heavier than air, a lower placement of the grilles will be required. Information on a contaminants specific gravity and toxicity should be available from chemical data sheets.

Alternately, the stale air may be drawn directly from the return air duct. When this system is used, the air handler's blower must constantly operate. The exhaust take-off connection must be at least 3 ft (1 m) from a directly connected ERV supply duct if both are connected to the same duct run. Note and compensate for the static pressure of the air handlers return system if the static pressure of the return in the air handler exceeds 0.1 to 0.15 in. w.g.

A damper located just prior to the ERV is required to balance the stale air exhausted with the fresh air supply entering the building.

Return air suction points should be located on the opposite side of the room from the fresh air inlet. The inlets may be in the ceiling or high on the walls and fitted with inlet grilles.

Fresh Air Supply System

The fresh air supply ductwork from the ERV may be directly connected to the return air duct of the forced air system. Check the air flow balance of the ERV with the air handler blower both "ON" and "OFF" to determine that it does not imbalance the ERV more than 10%. Also, it is advisable to include a short length of flex duct or other non-metallic connector in this hard ducted line in order to keep the ERV acoustically isolated and separately grounded (electrically) from the air handler. This will avoid a possible shock hazard to service people if a short to ground develops in one of the devices.

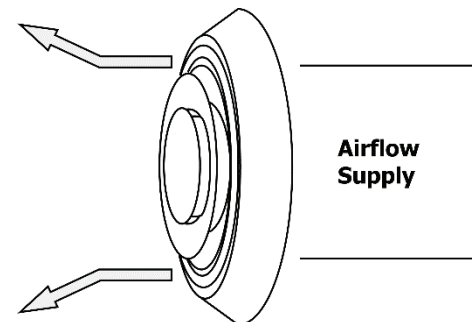

When installing an ERV, the designer and installer should be aware of local codes that may require smoke detectors and/or firestats in the HVAC or ERV ductwork. Because an ERV is designed to bring fresh air into the building, structures may require supply voltage interrupt when smoke or flame sensors are triggered, or when a central fire alarm system is activated.

It may be necessary to install a separate fresh air supply ductwork system if the heating is other than forced air.

Supply air grilles may be ceiling or high wall mounted. Avoid locating incoming fresh air grilles that could cause a direct draft on the occupants as the incoming air may be below room temperature. A reheat duct heater can be installed to improve occupant comfort.

7 WEATHERHOODS AND GRILLES

Outside Weatherhoods:

- The weatherhoods must have built-in “bird” screen with 1/4 in (6.35 mm) minimum mesh to prevent birds and rodents from entering the ductwork.

Recommended:

- no less than 10 ft. (3 m) apart from each other
- at least 18 in (46 cm) above snow line or ground level
- away from sources of contaminants, such as automobile exhaust fumes, gas meters, garbage cans, containers, etc.
- not exposed to prevailing winds
- The outside perimeter of the weatherhood must be caulked to prevent leakage into the building.
- The design and size of the weatherhoods or louvers chosen by the installer must allow for adequate free area. Water and debris penetration of the system is minimized when the airflow does not exceed 1000 FPM (5.08 m/s) free area velocity.

Ducting from the Weatherhoods:

- Galvanized sheet metal ducting with sufficient cross section with an integral single piece vapor barrier should be used to connect the ERV to the weatherhoods.
- A minimum R value of insulation should be equal to 4 (RSI 0.75)
- A good bead of high quality caulking (preferably acoustical sealant) and taping with a high quality aluminum foil tape is recommended to seal the duct to both the ERV and the weatherhood.

Techgrilles:

- The use of balancing dampers or adjustable grilles as supply air diffusers and air exhaust covers are recommended. TECHGRILLES™ are round, efficient, sound absorbing devices available in 4”, 5”, 6” and 8” (100, 125, 150, and 200 mm) models.

Part# 99-EAG4 4” diameter Techgrille

Part# 99-EAG5 5” diameter Techgrille

Part# 99-EAG6 6” diameter Techgrille

Part# 99-EAG8 8” diameter Techgrille

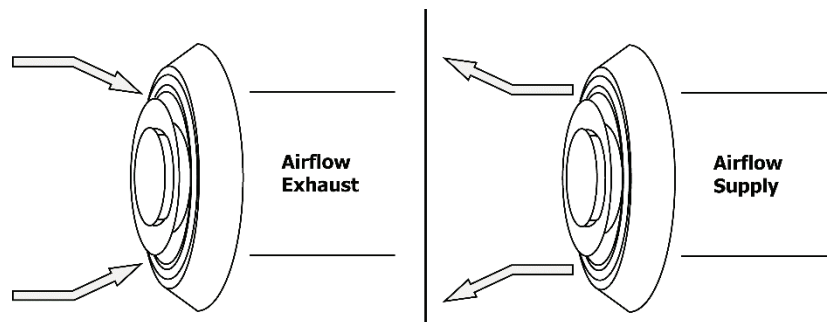

Attention

- All ducting must meet UL Class 1 requirements
- Design and install the fresh air intake in an area where the hoods will gather the freshest air.
- Do not use smaller mesh as it will be very susceptible to plugging up. Gravity dampers at the vents must not be used as they will restrict air flow and often “seize up”.

8 ELECTRICAL CONNECTIONS

It is recommended that a licensed electrician make all electrical connections. It is very important that the unit be properly grounded. The circuit must be sized to handle the Full Load Amperage (FLA) indicated on the name tag for the circuit.

	FLA Rating		
	HIGH	MED.	LOW
1230ERV-ECM	8.6	6.1	4.9
730ERV-ECM	5.7	3.7	2.3
530ERV-ECM	2.5	1.6	1.2
330ERV-ECM	2.1	1.4	1.0



Warning

- Verify the polarity of the power coming into the unit with a test lamp or multimeter. Connect the multimeter or test lamp probe to the wire being tested and the other probe to ground. The black line should be "live". If the white line is "live" the polarity is reversed and must be corrected. If both lines are live, the voltage is not 120VAC. The black open line from the unit should be connected to the live line and the white open line should be connected to the neutral line. Some units have a safety disconnect rocker switch located just outside of the electrical control box area. The switch disconnects the live line. Verify that it is working properly with a multimeter or test lamp. Always ensure the ERV is properly grounded before and after testing.



Caution

- The ERV is designed to operate with ducting. When first starting the ERV, measure the amp draw to each motor at each speed to ensure it is operating at or below the max rating.

9 FUNCTIONS AND CONTROLS

Basic Functions

Speed control is obtained by powering 24V to one of the designated speed taps. Select appropriate operational speed by installing the jumper wire between one of the designated speed taps on the Thermostat terminals on the micro process board. A jumper wire is factory installed in the low speed position.

Speed	Jumper Wire Placement	
High	R	W
Medium	R	Y
Low (factory setting)	R	G

Micro Processor Board

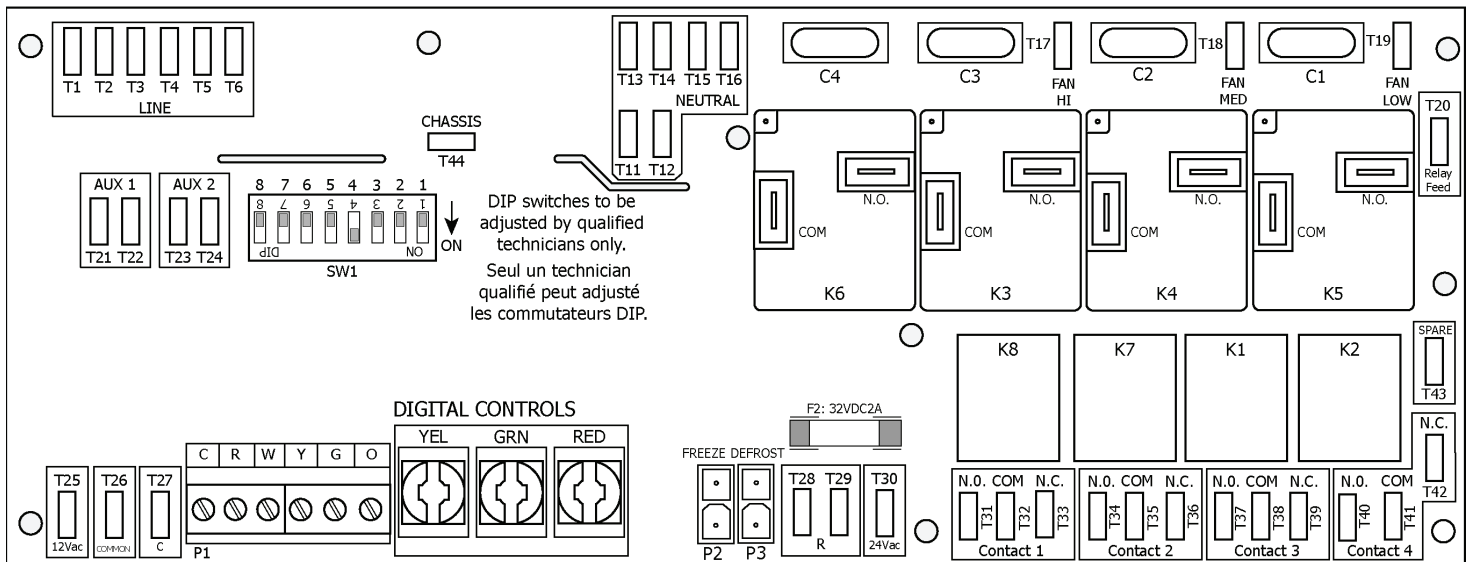

Optional Ventilation Control (99-BC02, 99-BC03, or 99-BC04)

See [Page 16](#) for installation on circuit board.

Optional 3 Speed Control (99-500)

See [Page 17](#) for installation on circuit board.

Optional Wireless Timer (99-DET02)

See [Page 19](#) for installation.

Optional Wireless Repeater (99-RX02)

See [Page 20](#) for installation.

Optional 20/40/60 Minute Timer (99-DET01)

See [Page 21](#) for installation on circuit board.

Note

- It is recommended to use the optional speed control Part # 99-500 in order to obtain 3 speed fan control.

10 MAIN WALL CONTROL

Ventilation Wall Control (99-BC02)

Operating Instructions:

- (1) ON/OFF Button
- (2) Dehumidistat Button
- (3) Fan Button
- (4) Fan Speed Indicator
- (5) Humidity Setting
- (6) ON/OFF light

Turning on the Control:

Press the ON/OFF Button . The ON/OFF light will illuminate.



Setting the Ventilation Speed:

Press the Fan Button  to select LOW or HIGH fan speed. The corresponding indicator light will illuminate. If both LO and HI indicator lights are off, the fan is OFF, but will turn ON if required by the Dehumidistat or remote timer (if installed).

Humidity Control:

Your unit will reduce indoor humidity when outdoor humidity levels are lower than indoor humidity levels. This feature is only effective when the outdoor temperature is below 59°F (15°C).

Setting the Dehumidistat:

Press the Dehumidistat button  until the dehumidistat indicator light is at the desired humidity setting. After a few seconds the dehumidistat indicator light will either flash or be on continuously. A flashing light indicates the humidity level is higher than the humidity setting and the unit is operating on high speed ventilation. A continuous light indicates the humidity level is lower than the humidity setting. The Dehumidistat will override the current speed setting to HIGH speed. The Dehumidistat function can be turned off by pressing the button  until the dehumidistat indicator light turns off.

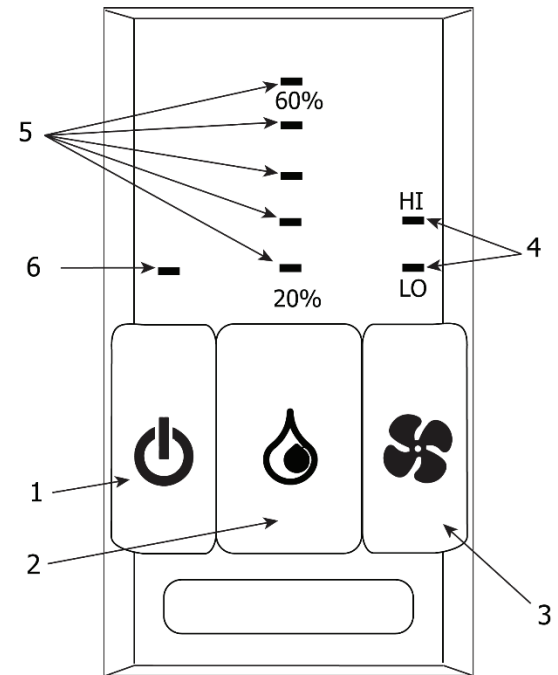

Attention

- Only one main control can be installed on your system.
- Recirculation is not available on all models.
- Timers will not function when mode of operation is set to "OFF", unless specifically installed for the function. (See Installation Guide for other options.)

11 MAIN WALL CONTROLS

Ventilation Wall Control (99-BC03)

Operating Instructions:

- (1) ON/OFF Button
- (2) Dehumidistat Button
- (3) Mode Button
- (4) Recirculation Mode Indicator
- (5) 20/40 Mode Indicator
- (6) Humidity Setting
- (7) LOW Fan Speed Indicator



Turning on the Control:

Press the ON/OFF Button . The LOW fan speed indicator will illuminate, and fan will turn to LOW speed.

Humidity Control:

Your unit will reduce indoor humidity when outdoor humidity levels are lower than indoor humidity levels. This feature is only effective when the outdoor temperature is below 59°F (15°C).

Setting the Dehumidistat:

Press the Dehumidistat Button  until the dehumidistat light is at the desired setting. After a few seconds the dehumidistat light will either flash or be on continuously. A flashing light indicates the humidity level is higher than the set point and that the unit is operating on HIGH speed ventilation. A continuous light indicates the humidity level is lower than the set point. The Dehumidistat will override the current speed setting to HIGH speed. The Dehumidistat function can be turned off by pressing the Dehumidistat Button  until the dehumidistat light turns off.

Setting the 20/40 Mode:

Press the Mode Button  until the 20/40 mode indicator light is illuminated. The 20/40 mode is a repeating cycle. The fan will run at LOW speed for 20 minutes, then turn OFF for 40 minutes. Some units are equipped to recirculate the air in your home during the 40-minute cycle with no ventilation. The control will automatically detect this feature and recirculate the air during the 40-minute cycle at LOW fan speed.

Recirculation Mode:

Some units are equipped to recirculate the air in your home without ventilating. Press the Mode Button  until the recirculation mode indicator light illuminates. Recirculation is in LOW speed.

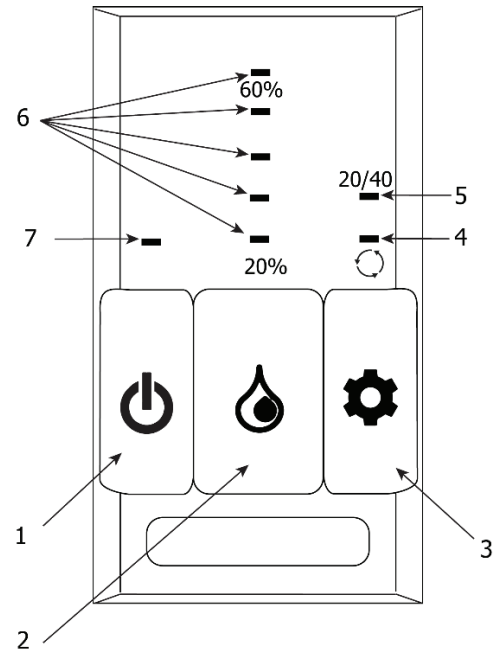

Attention

- Only one main control can be installed on your system.
- Recirculation is not available on all models.
- Timers will not function when mode of operation is set to "OFF", unless specifically installed for the function. (See Installation Guide for other options.)

12 MAIN WALL CONTROL

Ventilation Wall Control (99-BC04)

Operating Instructions:

- (1) ON/OFF Button
- (2) 20/40 Button
- (3) Fan Button
- (4) Fan Speed Indicator
- (5) 20/40 Mode Indicator
- (6) ON/OFF Indicator

Turning on the Control:

Press the ON/OFF Button . The ON/OFF indicator light will illuminate.

Setting the Ventilation Speed:

Press the Fan button  to select LOW or HIGH fan speed. The corresponding indicator light will illuminate. If both LO and HI indicator lights are off, the fan is OFF, but will turn ON if required by a remote timer (if installed).

Setting the 20/40 Mode:

After a fan speed has been selected, press the 20/40 button. The 20/40 mode indicator light will illuminate. The 20/40 mode is a repeating cycle. The fan will run at LOW or HIGH speed for 20 minutes, then turn OFF for 40 minutes. Some units are equipped to recirculate the air in your home during the 40-minute cycle with no ventilation. The control will automatically detect this feature and recirculate the air during the 40-minute cycle at the selected fan speed.

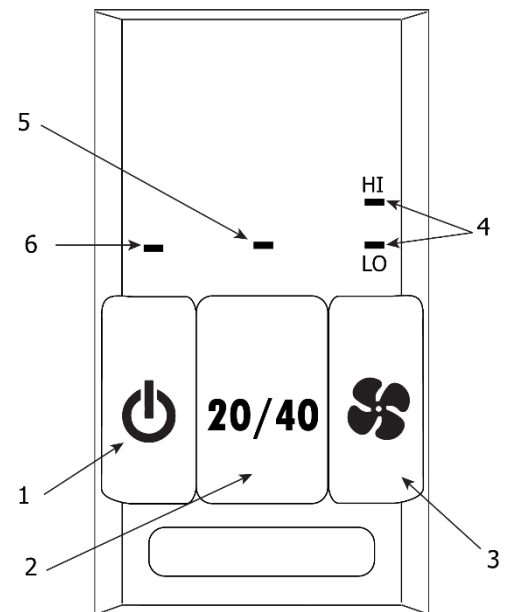

Attention

- Only one main control can be installed on your system.
- Recirculation is not available on all models.
- Timers will not function when mode of operation is set to "OFF", unless specifically installed for the function. (See Installation Guide for other options.)

13 MAIN WALL CONTROL

The 99-BC02, 99-BC03, 99-BC04 ventilation controls may either be installed onto a flush mounted electrical switch box or surface mounted onto a wall. Only one main control should be installed into a ventilation system.

Installation:

1. Carefully separate the face plate and the back plate by firmly pulling it apart. Keep the top/bottom vent openings clear (figure A).

2. Position the back plate in the desired location on the wall and mark the wall for the desired screw holes (figure B).

3. For mounting the main control without a Decora plate, break off the top and bottom tabs than position the back plate in the desired location on the wall and mark the wall for the desired screw holes (figure C)

4. Remove the back plate from the wall and mark the hole for the wires centered between the two screw holes (figure B or C).

5. Drill two 1/8 in. holes for the screws and wall anchors and drill one 1 in. x 0.75 in. hole for the wires.

6. Pull the 3 wire 20 gauge (min.), 100 ft length (max.), through the opening in the wall.

7. Connect the wires to the R, G, and Y terminals on the back plate (figure B or C).

8. Using the two supplied screws and anchors, install the back plate on the wall.

9. Attach the face plate to the back plate (figure A).

10. Connect the 3 wire 20 gauge (min.), 100 ft length (max.), to the RED, GRN, and YEL terminal on the Digital Controls terminal strip on the Aircom circuit board (figure D).

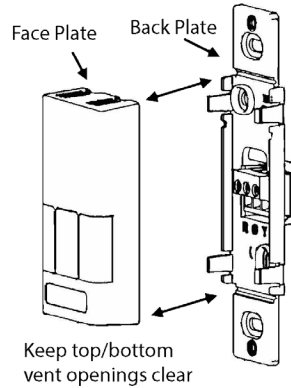

Figure A

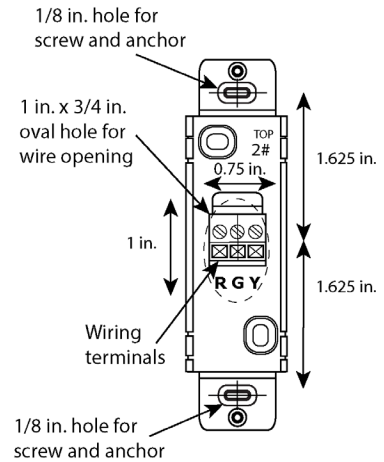

Figure B

Alternate Wall Mount

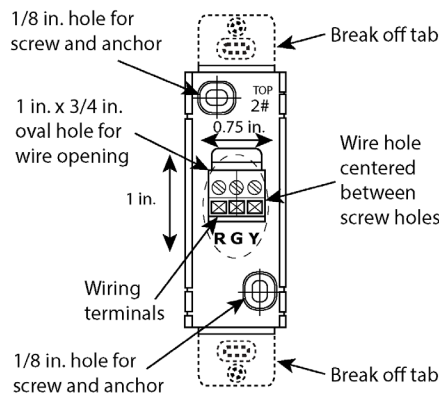

Figure C

DIGITAL CONTROLS

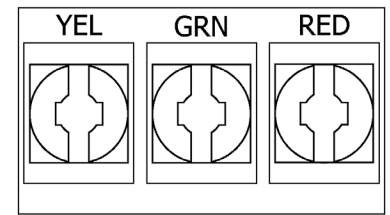

Figure D



Attention

- Use care when separating or attaching the face plate to avoid damaging the contact pins.

14 MAIN WALL CONTROL

3-Speed Control (99-500) Operation:

- (1) High Speed Fan
- (2) Medium Speed Fan
- (3) Low Speed Fan

Press the applicable Fan Speed button to set the fan speed. Press the applicable OFF button in order to turn the Fan Speed control off.

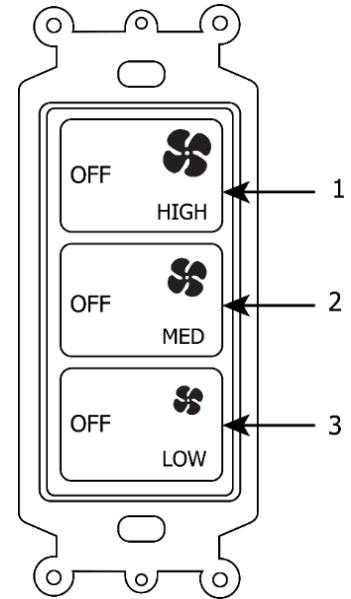

3-Speed Control (99-500) Installation:

Connect the wires to the R, W, Y, and G terminals on the Aircom circuit board as shown.

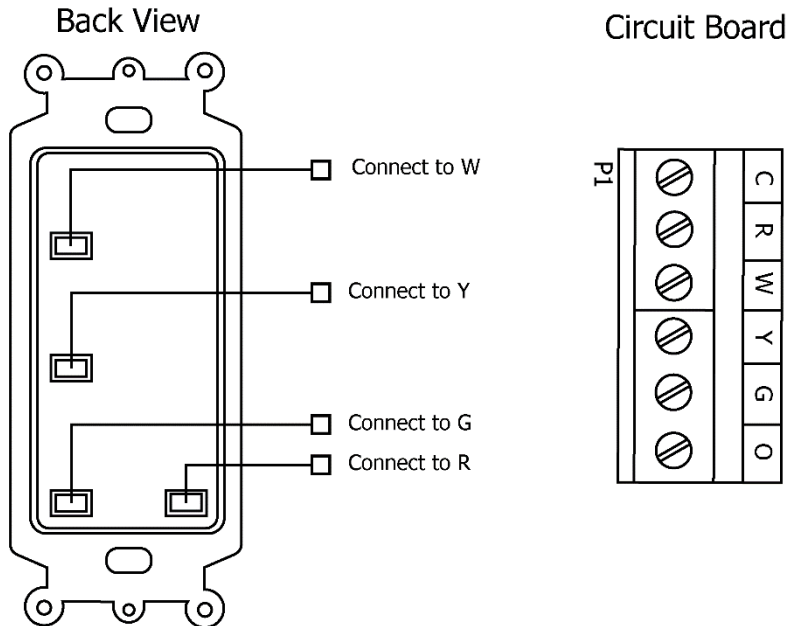

Attention

- Use 4 wire; 20-gauge wire (minimum)
- When used in conjunction with the 99-BC04, the BC04 control must be ON for the 99-500 control to operate. The 99-BC04 will override the 99-500 control when the control is set to HIGH speed

15 TIMERS AND REPEATERS

20/40/60 Minute Wireless Timer (99-DET02) Operation:

- (1) Select Button
- (2) 20/40/60 minute status lights
- (3) Red LED battery indicator

Press the Select Button on the timer to initiate high speed ventilation for 20, 40, or 60 minutes. The 20/40/60 minute status lights indicate high speed operation. To cancel the high speed fan operation, press the Select Button until the 20/40/60 minute status lights are no longer illuminated.

When the battery in the timer needs to be replaced, the red LED Battery Indicator will illuminate.

When paired to the digital wall control, the wireless timer may be moved to a remote location in the home such as a bathroom. Wireless timers have an estimated range of 40 ft with no obstructions

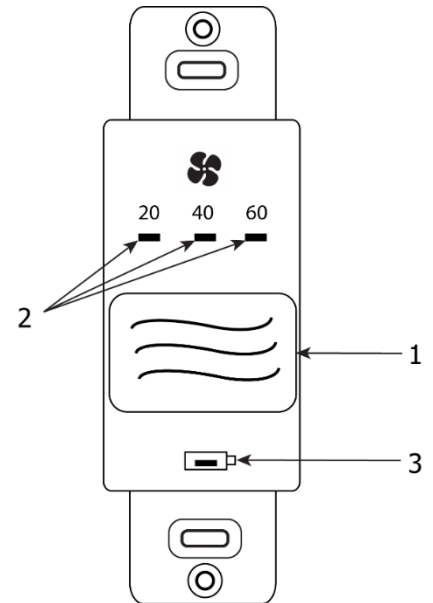

Replacing the Timer Battery (99-DET02):

- (4) Battery
- (5) Face plate
- (6) Back plate

- a) Remove the face plate by separating it from the back plate. On the back of the face plate the battery will be exposed.
- b) Replace the battery and re-attach the face plate to the back plate.

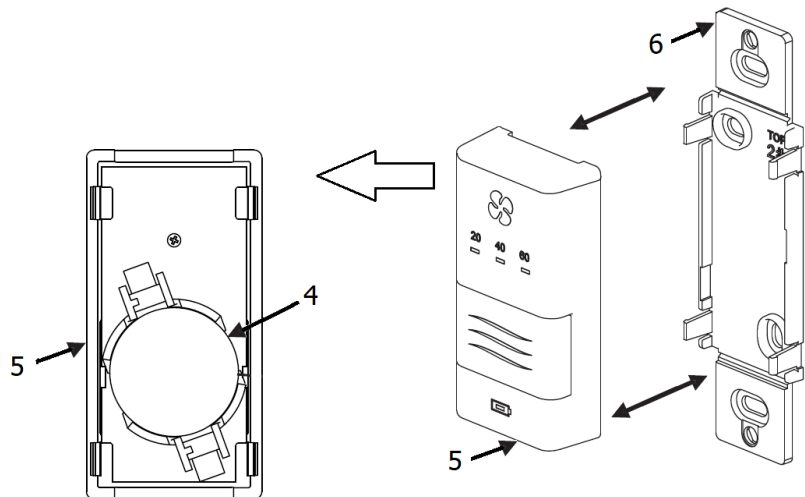

Attention





- Be careful not to damage the tabs on the back plate when re-attaching the face plate.

16 TIMERS AND REPEATERS

Wireless 20/40/60 Minute Timer (99-DET02)

The timers may be installed onto a flush mounted electrical switch box or it may be surface mounted onto a wall.

Pairing:

1. Remove the battery from the back of the timer, if installed.
2. Press the ON/OFF Button  on the main control to turn it on.
3. **BC02, BC03, or BC04:** Press the left and right buttons ( and  or ) simultaneously on the main control. The bottom row LEDs will begin flashing. This indicates the main control is now in pairing mode.
4. Keep the timer within 16 in. of the main control when pairing.
5. Install the battery into the remote timer. The four lights will immediately flash five times. The red battery light will remain on for 12 seconds, then the 40 minute status light will flash. The 20, 40, and 60 minute status lights will flash for up to 30 seconds and then stop.
6. Press the Power Button  on the main control to exit pairing mode.
7. Press the Select Button on the timer to test that pairing was successful (figure A).
 - If the ERV initiates HIGH fan speed ventilation, pairing was successful.
 - If the ERV does not initiate HIGH fan speed ventilation, pairing was not successful. Un-pair the timer and return to step 1 of the pairing procedure and restart the pairing process.
8. Pair additional timers as necessary by repeating steps 1 through 8.

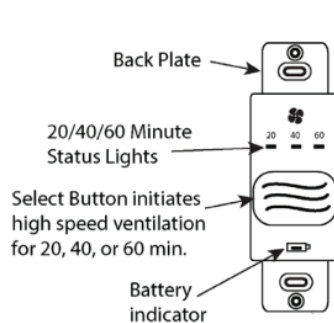

Figure A

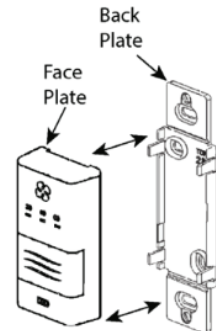

Figure B

Alternate Wall Mount

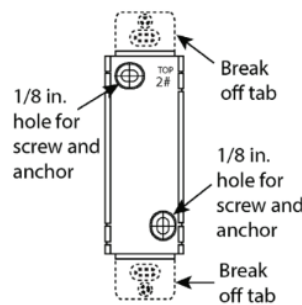

Figure C

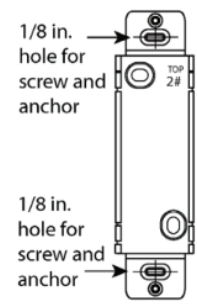

Figure D

Un-pairing:

1. Remove the battery from the back of the timer.
2. Press and hold the Select Button on the front of the timer (figure A).
3. While holding the Select Button, reinstall the battery in the timer. Continue holding the Select Button until the 20, 40, and 60 minute status light begins flashing (this can take up to 30 seconds). The timer will now be unpaired with the main control (figure A).

Installation:

1. Separate the face plate from the back plate by firmly pulling apart (figure B).
2. For mounting the main control without a Decora plate, break off top and bottom tabs (figure C).
3. Place the back plate of the main control in the desired location on the wall and pencil mark the top and bottom screw holes. Drill two 1/8" holes (figure C or D).
4. Attach the back plate to the wall using the two supplied screws and anchors.
5. Attach the face plate to the back plate (figure B).

Attention

- The wireless timers and repeaters must be paired to the main control of the ERV. This process is called "Pairing". Multiple timers and repeaters can be paired to the digital wall control.

17 TIMERS AND REPEATERS

99-RX02 Repeater

- (1) Green LED
- (2) Red LED
- (3) Power Plug

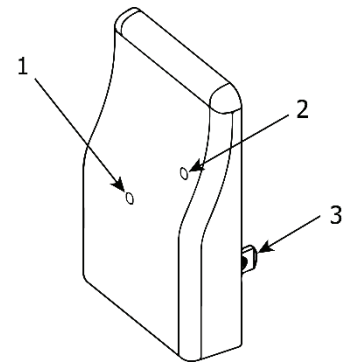





The wireless repeater is used to extend the range of the 99-DET02 wireless timers. The repeater plugs directly into a 120V power outlet. The 99-RX02 repeater wirelessly connects to the main wall control as well as the 99-DET02 wireless timers.

The 99-RX02 repeater should be installed at the halfway point between the 99-DET02 wireless timer and the main wall control if the timer is out of range. The LED will indicate the repeater’s connection strength to the main wall control per the table below. Re-adjust the repeater’s position as necessary.

LED Colour	Connection	Action
Solid Green	Good	No further adjustments are required.
Flashing Green	Moderate	The repeater will function properly but shouldn’t be moved further away from the main wall control.
Red	Bad	The repeater needs to be moved closer to the main wall control.

Pairing:

1. Turn on the main control by pressing the ON/OFF button .
2. **BC02, BC03 or BC04 control:** Press the left and right buttons simultaneously on the main control ( and ). The bottom row LED's will begin flashing. This indicates that the main control is now in pairing mode.
3. The RX02 Repeater must be powered within 16 in. of the main control for pairing. If an outlet is not available an extension cord should be used to power the Repeater initially for pairing.
4. Plug the repeater into the power outlet. The green light will flash after approximately 12 seconds indicating that the repeater is paired with the main control.
5. Press the ON/OFF button  on the main control to exit pairing mode and the repeater may now be unplugged and moved to its permanent location.
6. To pair additional repeaters with the same main control, repeat steps 1 through 5 until all repeaters have been paired.



Attention

- The repeaters are to be plugged directly into a 120V power outlet.

18 TIMERS AND REPEATERS

20/40/60 Minute Timer (99-DET01) Operation:

- (1) Select Button
- (2) 20/40/60 minute status lights

Press the Select Button on the timer to initiate high speed ventilation for 20, 40, or 60 minutes. The 20/40/60 minute status lights indicate high speed operation.

Lockout mode is useful if you wish to disable the timer:

- Enable Lockout Mode by holding the Select Button for 5 seconds.
- Disable Lockout Mode by holding the Select Button for 5 seconds.

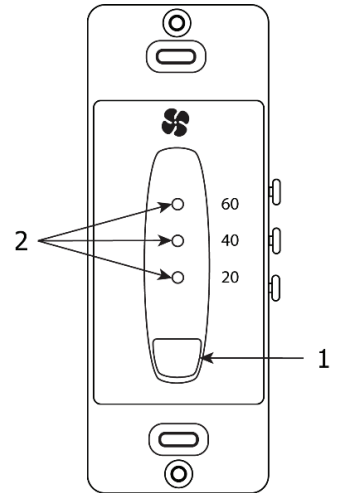

20/40/60 Minute Timer (99-DET01) Installation:

Connect the wires from the Y, R, and G terminals on the timer to the YEL, RED, and GRN terminals on the circuit board as shown.

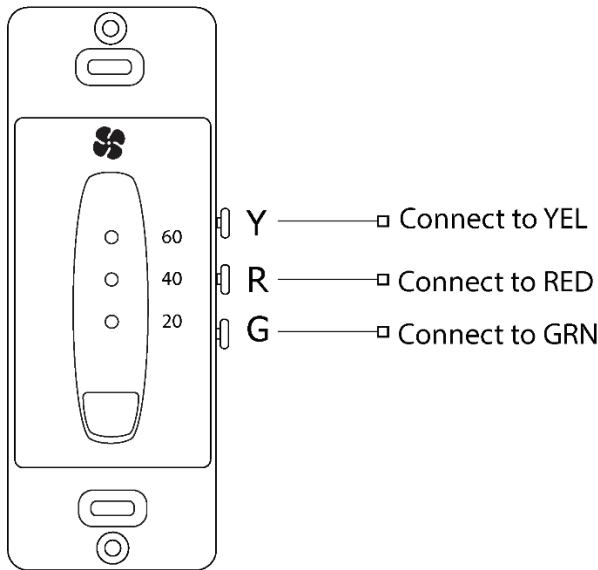

Circuit Board

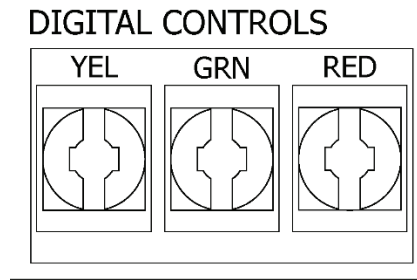

Note

- Timers mount in standard 2" x 4" electrical boxes.
- Wire multiple timers individually back to the unit.
- Use 3 wire; 20-gauge wire (minimum)

19 AIRCOM RELAYS & INTERLOCKING TO A FURNACE/AIR HANDLER

The circuit board has three available "dry contact" relays. Contact 3 is not available. Maximum 115V, 10 amp resistive load.

Contact 1

This relay initiates (connects COM to N.C.) whenever the ERV is in defrost.

Contact 2 and 4

These relays initiate (connect COM to N.O.) whenever the ERV fans are operating.

- Use contact 2 or 4 to interlock the ERV to an Air Handler or Furnace.

Note: Connecting the ERV as illustrated will ensure the Air Handler Blower Motor is operating whenever the ERV is ventilating.

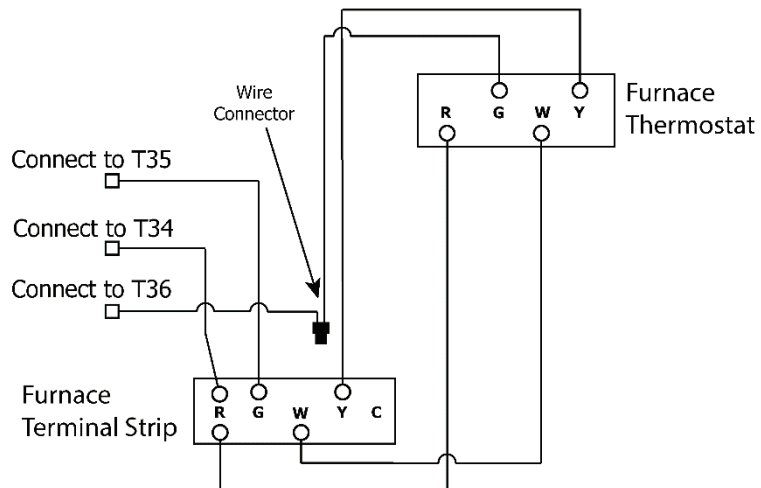
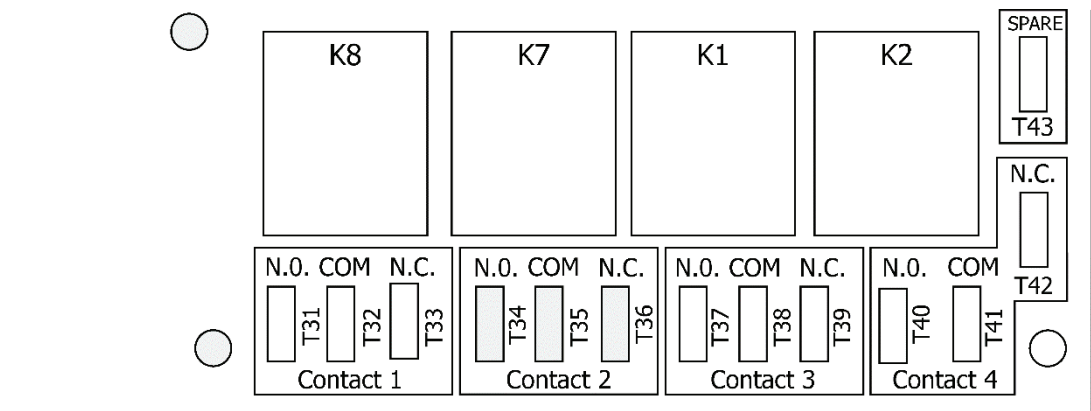

Caution

- Consideration must be given to competing air flows when connecting the ERV in conjunction with an Air Handler/Furnace Blower system.

20 FAN DEFROST

The 330, 530, 730, and 1230 units are equipped with an electronically controlled fan defrost system to remove frost that collects on the warm air side of the heat exchanger core. When the outside air temperature drops below 27°F (-3°C), defrost is activated which provides for an automatic defrost cycle. During the automatic defrost cycle the fresh air supply is shut off while the exhaust fan continues to operate. This allows warm inside air to flow through the heat exchanger core melting frost accumulation. After the defrost period, the fresh air supply fan automatically returns to the normal speed and fresh outside air continues to be drawn into the building. The defrost cycle repeats automatically until the air temperature rises above 27°F (-3°C).

- If the indoor air temperature is too low, the defrost time may need to be increased.
- The unit must be mounted level. The warranty will be void if these conditions are not met.

Defrost Time Adjustment

DIP switch #8 (located on the Aircom circuit board) will adjust the defrost time. Do not change to any other DIP switch configuration.

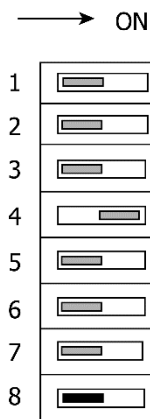

Factory Setting (DIP switch #8 OFF)

The sequence of events for this defrost mode at 27°F (-3°C) is:

1. Both fans will stop for one minute.
2. The ERV exhaust motor will initiate and operate for 4 minutes.
3. Both ERV motors (exhaust and intake) will operate for 30 minutes.
4. The cycle repeats.

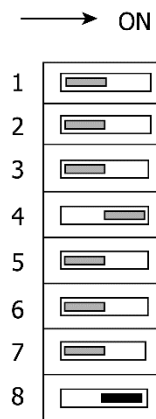

Increased Defrost Time (DIP switch #8 ON)

Cooler climates may require a more aggressive defrost cycle:

1. Both fans will stop for one minute.
2. The ERV exhaust motor will initiate and operate for 4 minutes.
3. Both ERV motors (exhaust and intake) will operate for 20 minutes.
4. The cycle repeats.

Caution

- Change DIP switch only as illustrated on this page. Do not adjust any other switches.

21 BALANCING THE AIRFLOWS

It is necessary to have balanced air flows in an ERV. The volume of air brought in from the outside must equal the volume of air exhausted by the unit. If the air flows are not properly balanced, then;

- The ERV may not operate at its maximum efficiency
- A negative or positive air pressure may occur in the building
- The unit may not defrost properly
- Failure to balance ERV properly may void warranty

Read the Application Warning on the front of this manual!

Prior to balancing, ensure that:

1. All sealing of the ductwork system has been completed.
2. All the ERV's components are in place and functioning properly.
3. Balancing dampers are fully open.
4. Unit is on HIGH speed.
5. Air flows in branch lines to specific areas of the house should be adjusted first prior to balancing the unit. A smoke pencil used at the grilles is a good indicator of each branch line's relative air flow.
6. After taking readings of both the stale air to the ERV duct and fresh air to the house duct, the duct with the lower CFM ([L/s] velocity) reading should be left alone, while the duct with the higher reading should be adjusted back to match the lower reading.
7. Return unit to appropriate fan speed for normal operation

Balancing Procedure

The following is a method of field balancing an ERV using a Pitot tube, advantageous in situations when flow stations are not installed in the ductwork. Procedure should be performed with the ERV on high speed.

1. The first step is to operate **all** mechanical systems on high speed, which have an influence on the ventilation system, i.e. the ERV itself and the forced air furnace or air handler if applicable. This will provide the maximum pressure that the ERV will need to overcome and allow for a more accurate balance of the unit.
2. Drill a small hole in the duct (about 3/16"), three feet downstream of any elbows or bends, and one foot upstream of any elbows or bends. These are recommended distances, but the actual installation may limit the amount of straight duct.
3. The Pitot tube should be connected to a manometer capable of reading 3 digits of resolution. The tube coming out of the top of the pitot is connected to the high pressure side of the gauge. The tube coming out of the side of the pitot is connected to the low pressure or reference side of the gauge. Insert the Pitot tube into the duct; pointing the tip into the airflow.
4. For general balancing it is enough to move the pitot tube around in the duct and take an average or typical reading.
5. Repeat this procedure in the other (supply or return) duct.
6. Determine which duct has the highest airflow (highest reading on the manometer).
7. Adjust the higher airflow by adjusting the field supplied damper. The flows should now be balanced. Actual airflow can be determined from the gauge reading. The value read on the gauge is called the velocity pressure. The Pitot tube comes with a chart that will give the air flow velocity based on the velocity pressure indicated by the gauge. This velocity will be in either feet per minute or meters per second. To determine the actual airflow, the velocity is multiplied by the cross sectional area of the duct being measured.



Attention

- Continuous, excessive, positive pressure may drive moist indoor air into the external walls of the building. Once inside the external walls, moist air may condense (in cold weather) and degrade structural components or cause locks to freeze.
- Continuous, excessive, negative pressure may have several undesirable effects. In some geographic locations, soil gases such as methane and radon gas may be drawn into the home through basement or ground contact areas and may also cause the backdrafting of vented combustion equipment.

22 BALANCING THE AIRFLOWS

Example:

This is an example for determining the airflow in a 6 in. (0.5 ft) duct.

- The Pitot tube reading was 0.025 inches of water. From the chart, this is 640 ft/min.

The 6 in. (0.5 ft) duct has a cross sectional area of:

$$A = \pi r^2 = [\pi d^2] / 4$$

$$A = [3.14 \times (0.5 \text{ ft})^2] / 4$$

$$A = 0.2 \text{ ft}^2$$

The airflow is then: (640 ft./min.) x (0.2 ft²) = 128 cfm

For your convenience, the cross sectional areas of some common duct sizes are listed below:

DUCT. DIAM. (inches)	CROSS SECTION AREA (sq. ft.)
5 (127 mm)	0.14
6 (152 mm)	0.20
7 (178 mm)	0.27

The accuracy of the air flow reading will be affected by how close to any elbows or bends the readings are taken. Accuracy can be increased by taking an average of multiple readings as outlined in the literature supplied with the Pitot tube.

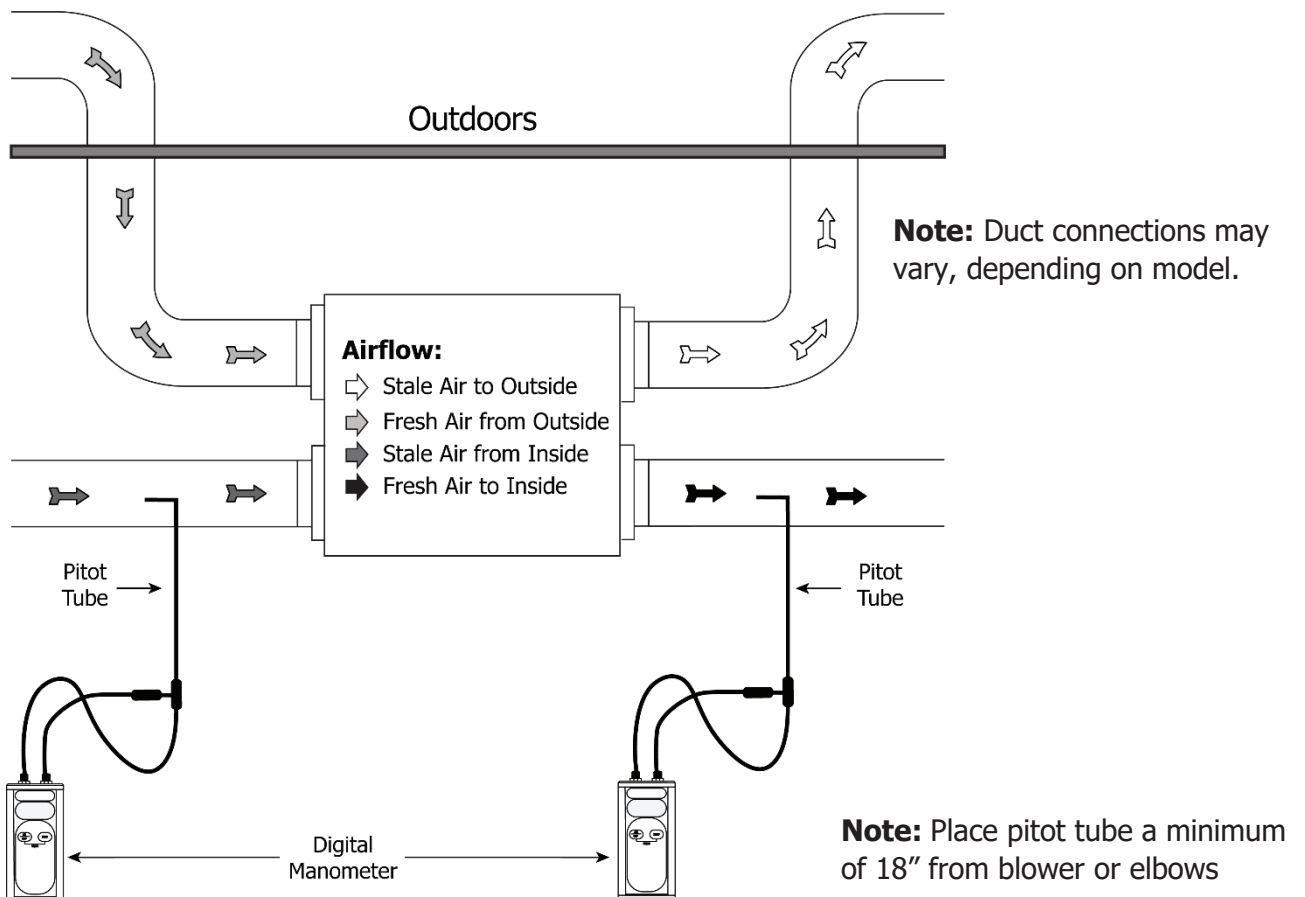

23 SERVICE AND MAINTENANCE

Servicing your ERV on a regular schedule will result in optimum operating efficiencies and prolonged life of the equipment. Due to numerous applications in which this equipment can be installed, it is difficult to predict servicing intervals. In certain situations where there is heavy smoke, servicing the equipment every one to two months may be needed; whereas ventilating a meeting room for carbon dioxide may only need service every six months to a year.

Motor

Access to the motor is through the front service doors. Note heat exchanger core can be removed to provide more room. See **ERV Core** in this section. The motor is an electronically commutated motor (ECM) which uses a sleeve mechanism to steady the shaft.

ERV Core

Remove core(s) and vacuum or use low pressurized air to clean core(s). Do not wash or submerge in water. With the core(s) in its proper position, place the bottom corner into its guide rail support, then place the left side, the right side and finally the top corner into place in the same fashion. Once the core(s) is in place, push the core evenly into the cabinet until it reaches the back. Note the core(s) will protrude slightly out from the front of the cabinet, this is so the access doors, when closed, ensures a tight fit.

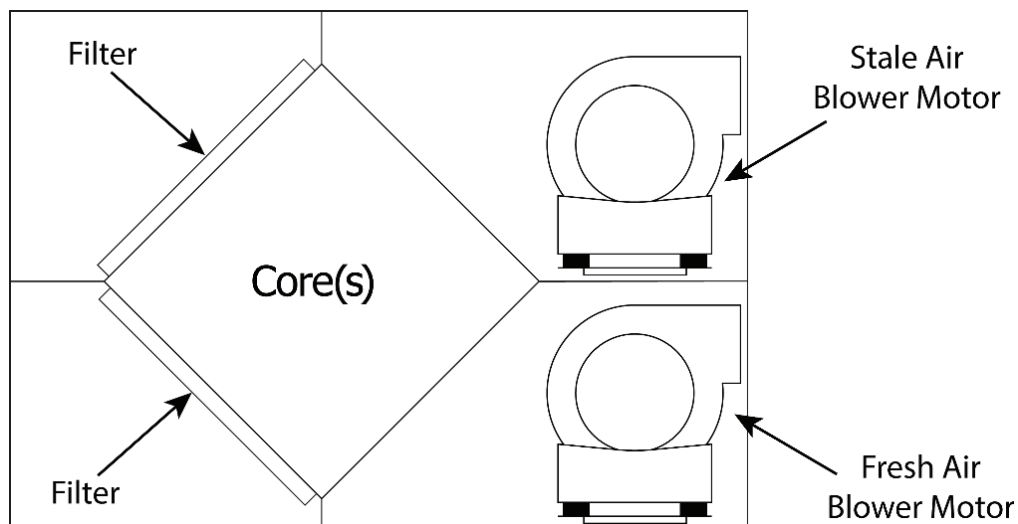

Note: When removing cores and filters, note their location and arrangement.

24 SERVICE AND MAINTENANCE

Filters

Open front service door to access the filters located in both supply and exhaust air streams. Note to remove and install filters, it may be easier to first remove the core(s). Refer to **ERV Core**. The filters are designed to stop large particles from entering in the core. The filters are fastened in place by a metal spring rod. To remove filters from core(s) simply pull the rod from one end, outward until free from core lip, and remove. Only use cold water with a mild detergent to wash the filters. Do not use harsh chemicals. The time between filter service will depend on the application the ERV has been installed in. It can be as often as one - two months or at the very least, cleaned every six months.

Duct Work

It is a good idea to inspect ducting, outside weather hoods (wall caps), and grilles for blockage and dirt buildup, at least every six months. Outside weatherhoods should be protected by a bird screen which can plug up with debris. Also, it is a good idea to visually confirm that the fresh air supply is free from any sources of contamination, such as other vented combustion equipment added after the fact.

General Maintenance

As a final step in a routine maintenance schedule, it is a good idea to confirm operation of the system, checking speed control functions and remote control operation, if applicable. Wipe the inside of the cabinet to remove dust and cobwebs as needed. It is a good idea to keep a service/maintenance log of the unit.

25 REVERSE INSTALLATION OF THE ERV

Electrical Box Removal:

1. Remove the door panels from the ERV by loosening the screws located on the face of the doors.
2. Remove the electrical box cover by removing the 4 screws fastening the cover in place.
3. Disconnect the motor wires coming through the bottom of the electrical box from the circuit board, and relay, and remove from the electrical box.
4. Pull motor wires for lower blower through hole in blower divider panel.
5. Disconnect thermistor from circuit board and remove from electrical box.
6. Remove the 4 screws securing the electrical box to the cabinet of the ERV.

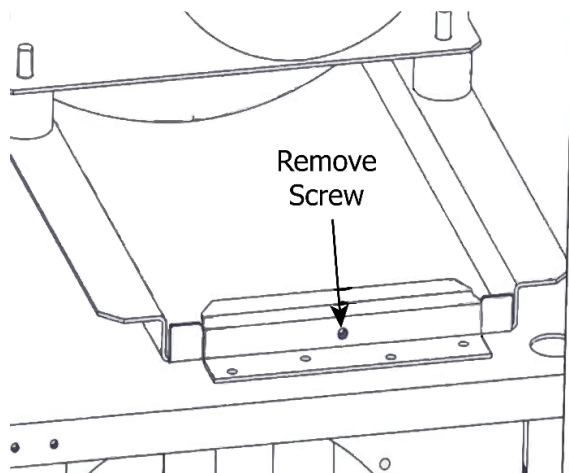

7. Remove the ground continuity screw from both the upper and lower blower pans securing them to the pan stops.
8. Remove the plastic snap bushing from the hole in the top core support panel where the damper wires were removed from, and install a snap plug to seal the hole, found in the manual bag.
9. Remove the snap plug from the hole in the top core support panel and install a plastic snap bushing in hole.
10. Remove the two snap plugs from the opposite side of the cabinet for electrical and control wires.

Reinstalling the Electrical Box:

1. Install the two snap plugs in the cabinet holes on the side of the ERV which electrical box was originally removed from.
2. Route wires for both blower motors to opposite side of ERV cabinet where electrical box is to be installed.
3. Install the grounding continuity screw in both the upper and lower blower assemblies on the opposite side of the ERV where electrical box is now installed.
4. Fasten the electrical box to the cabinet of the ERV using the 4 screws that were previously removed.
5. Remove the snap plug from the blower divider panel and install plastic snap bushing provided in manual bag.
6. Install snap plug in hole in blower divider panel where lower blower motor wires were originally removed from.
7. Route the lower blower motor wires through the hole in the divider panel into the electrical box.
8. Route upper motor wires into the electrical box.
9. Connect the motor wires to the circuit board, relays and capacitors using wiring diagram found in manual for reverse installations.
10. Route thermistor wire from electrical box, through hole in the top core support panel, and secure the blue end to the thermistor bracket in front of the damper motor using a plastic cable tie.
11. Connect the thermistor to the circuit board in the electrical box.
12. Putty holes closed in blower divider panel and top core support panel with wires protruding through.
13. Install the large single door panel on the now back of the cabinet where electrical box was removed from and fasten using the eight machine screws.
14. Reversing of the ERV is now complete. Continue with the installation of the ERV.

26 TROUBLESHOOTING

Refer to the following table for troubleshooting the ERV unit.

Table 17.1 – Troubleshooting Procedures

SYMPTOM	CAUSE	SOLUTION
Poor airflows	<ul style="list-style-type: none"> • 1/4 in. (6mm) mesh on outside hood is plugged • Filters plugged • Core obstructed • House grilles closed or blocked • Dampers are closed if installed • Poor power supply at site • Ductwork is restricting ERV • Improper speed control setting • ERV airflow improperly balanced 	<ul style="list-style-type: none"> • Clean exterior hoods or vents • Remove and clean filter • Remove and clean core • Check and open grilles • Open and adjust dampers • Have electrician check supply voltage • Check duct installation • Increase the speed of the ERV • Have contractor balance ERV
Supply air feels cold	<ul style="list-style-type: none"> • Poor location of supply grilles, the airflow may irritate the occupant • Outdoor temperature extremely cold 	<ul style="list-style-type: none"> • Locate the grilles high on the walls or under the baseboards, install ceiling mounted diffuser or grilles so as not to directly spill the supply air on the occupant (i.e. over a sofa) • Turn down the ERV supply speed. A small duct heater (1 kW) could be used to temper the supply air • Placement of furniture or closed doors is restricting the movement of air in the home • If supply air is ducted into furnace return, the furnace fan may need to run continuously to distribute ventilation air comfortably

27 TROUBLESHOOTING

Refer to the following table for troubleshooting the ERV unit.

Table 17.1 – Troubleshooting Procedures (cont.)

SYMPTOM	CAUSE	SOLUTION
Humidity levels are too high condensation is appearing on the windows	<ul style="list-style-type: none"> • Dehumidistat is set too high • ERV is not sized to handle a hot tub, indoor pool etc. • Lifestyle of the occupants Moisture coming into the home from an unvented or unheated crawl space • Moisture is remaining in the washroom and kitchen areas • Condensation seems to form in the spring and fall ERV is set at too low a speed 	<ul style="list-style-type: none"> • Set Dehumidistat lower • Cover pools, hot tubs when they are not in use • Avoid hanging clothes to dry, storing wood and venting clothes dryer inside. Firewood may have to be moved outside • Vent crawl space and place a vapor barrier on the floor of the crawl space • Ducts from the washroom should be sized to remove moist air as effectively as possible, use of a bathroom fan for short periods will remove additional moisture • On humid days, as the seasons change, some condensation may appear, but the homes air quality will remain high with some ERV use Increase speed of the ERV
Humidity levels are too low	<ul style="list-style-type: none"> • Blower speed of ERV is too high • Lifestyle of occupants • ERV airflows may be improperly balanced 	<ul style="list-style-type: none"> • Decrease ERV blower speed • Humidity may have to be added using humidifiers • Have contractor balance ERV airflows
ERV and/or ducts frosting up	<ul style="list-style-type: none"> • ERV airflows are improperly balanced • Malfunction of the ERV defrost system 	<ul style="list-style-type: none"> • Note: minimal frost build-up is expected on cores before unit initiates defrost cycle functions • Have HVAC contractor balance the ERV • Ensure damper defrost is operating during self-test
Condensation or ice buildup in insulated duct to the outside	<ul style="list-style-type: none"> • Incomplete vapor barrier around insulated duct • A hole or tear in outer duct covering 	<ul style="list-style-type: none"> • Tape and seal all joints • Tape any holes or tears made in the outer duct covering, ensure that the vapor barrier is completely sealed
Excessive vibration	<ul style="list-style-type: none"> • Dirt on fan wheels 	<ul style="list-style-type: none"> • Have contractor service ERV

330ERV-ECM/ 530ERV-ECM / 730ERV-ECM / 1230ERV-ECM

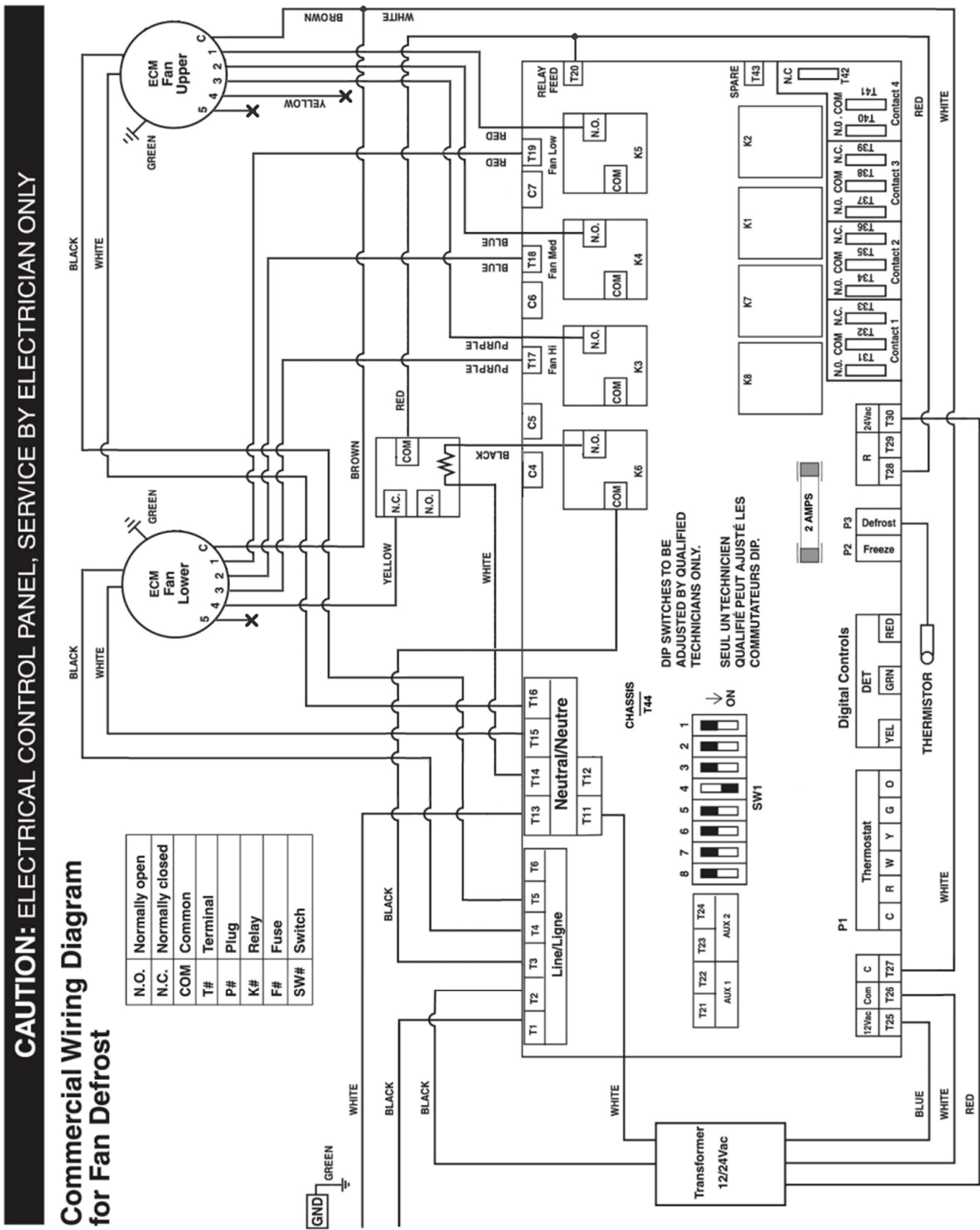

29 WARRANTY

AIRIA BRANDS INC.® (AIRIA) warrants to the original purchaser of the LIFE BREATH® model and accessories referred to below, to be free from manufacturing defects.

This Limited Warranty is personal to AIRIA® and is in effect from the installation date, but no later than 12 months after the date the product was manufactured (if the installation date cannot be verified, the warranty period will begin on the date of manufacture). The serial number can be used to determine the date of manufacture: XX XX MMDDYY ###; or MMDDYY ###. The warranty is dependent on the type of unit:

Type of Unit	Warranty
HRV Residential	Lifetime on the Core / 5 years on other components
HRV Commercial	15 years on the Core / 2 years on other components
ERV Residential	5 years on the Core / 5 years on other components
ERV Commercial	5 years on the Core / 2 years on other components
Accessories (e.g. controls and timers)	1 year
Replacement Parts (e.g. motor)	1 year
Clean Air Furnace (HRV)	Lifetime on the Core / 2 years on other components
Clean Air Furnace (ERV)	5 years on the Core / 2 years on other components
Air Handler	5 years
TFP	5 years

Damage resulting from all other causes, including but not limited to: lightning, hurricane, tornado, earthquake or any other acts of God; improper installation, modification, alteration or misuse of the LIFE BREATH® unit or its operation in a manner contrary to the instructions accompanying the unit at the time of sale; accidental or intentional damage, neglect, improper care, or other failure by the owner to provide reasonable and necessary maintenance of the product; any attempt at repair by an unauthorized service representative or not in accordance with this warranty; or any other causes beyond the control of AIRIA®, are excluded from this warranty.

If you feel that the LIFE BREATH® unit you purchased is not free from manufacturing defects, please refer to <https://www.lifebreath.com/homeowners-2/find-a-contractor/> to find the name of your nearest dealer in order to repair the product. The labour required to install any replacement part(s) is not covered by AIRIA®.

AIRIA® reserves the right to replace the entire unit or to refund the original purchase price in lieu of repair.

AIRIA® MAKES NO EXPRESS WARRANTIES, EXCEPT FOR THOSE SET FORTH HEREIN AND SHALL NOT BE LIABLE FOR ANY INCIDENTAL, SPECIAL OR CONSEQUENTIAL DAMAGES WITH RESPECT TO LIFE BREATH® COVERED BY THIS WARRANTY. AIRIA'S COMPLETE LIABILITY AND THE OWNER'S EXCLUSIVE REMEDY BEING LIMITED TO REPAIR OR REPLACEMENT ON THE TERMS STATED HEREIN. ANY IMPLIED WARRANTIES, INCLUDING BUT NOT LIMITED TO THE IMPLIED WARRANTY OF MERCHANTABILITY AND OF FITNESS FOR ANY PARTICULAR PURPOSE, ARE EXPRESSLY EXCLUDED.

NO PERSON IS AUTHORIZED TO CHANGE THE WARRANTY IN ANY WAY OR GRANT ANY OTHER WARRANTY UNLESS SUCH CHANGES ARE MADE IN WRITING AND SIGNED BY AN OFFICER OF AIRIA®.

MODEL NO.: _____
UNIT SERIAL NO.: _____
INSTALLED BY: _____
DATE: _____